

1 - Upper Assembly & Components

- 807 Extrusion - 7' Luff
- 809 Connector - 8.890" Bottom
- 810 Connector - 7"
- 812 Feeder
- HFS192 Fastener - 10-32 x 3/8" 18-8 Stl Ov
- 865 Locking Collar - w/Insert
- 865Collar Locking Collar
- HFG121 Plastic Insert
- 819 Connector Screw Set (30)
- HFS179 Fastener - 5/32" x .156" Stl Fi #6
- 820 Wedge Set (17)
- HFG216 Connector Wedge
- 870 Trim Cap 1
- 888 Extrusion - 2' Luff
- 889 Halyard Swivel
- 4456 Label - 3/8" x 2 1/8"
- 2112 Shackle - (6 mm) 1/4" Twist
- 2110 Shackle - (6 mm) 1/4" Bow
- HBB7 Ball Bearing - 3/8" Torlon (order 76)
- HFG147 Snap Ring - Small
- HFG383 Snap Ring - Large (order 2)
- 893 Torque Tube
- 4753 Label - Small Red Oval
- HFG726 Set Torque Tube Clamp Screws (2)
- HFS333 Fastener - M6 x 1.0 x 30 316 Sk Cap
- HFG136 Extrusion Set (6 Long, 1 Short)
- 807 Extrusion - 7' Luff
- 888 Extrusion - 2' Luff
- HFG633 Fastener Set - Torque Tube (3)
- HFS334 Fastener - M5 x .8 x 10mm A4 Sk Cap

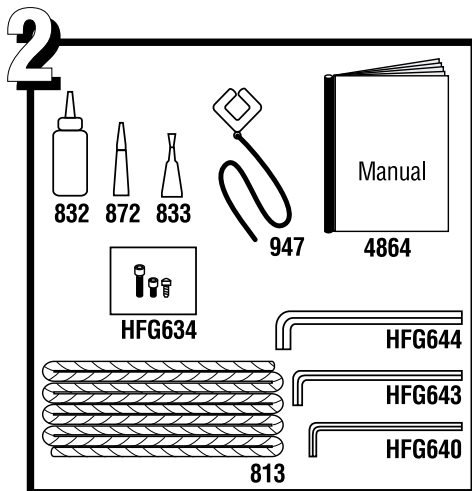

2 - Accessories

- 4114 Manual - Furling
- 813 Line - 5/16" x 70'
- 832 Loctite - 1 Red
- 833 Loctite - Blue
- 872 Super Glue
- 947 Prefeeder - Phenolic w/Line
- HFG634 Fastener Set - Spare
- HFG640 Wrench - M4 Allen Short
- HFG643 Wrench - M5 Allen Long
- HFG644 Wrench - M6 Allen Short

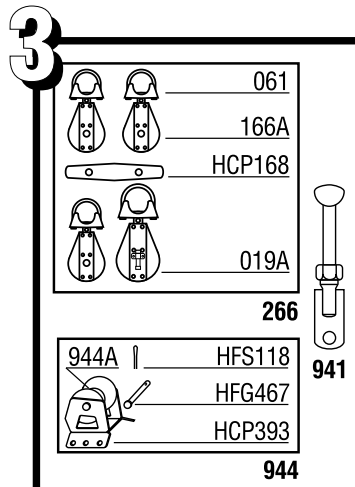

3 - Optional Parts

- 266 Kit - Small Lead Block
- 019A Block - 2.25" Hex Stbd
- 061 Stanchion Mount Base
- 166A Block - Bullet Swivel
- HCP168 Cleat - 4" Black
- 942 Isomat Adapter
- 944 Halyard Restrainer - Small
- 944A Sheave & SS Inner Race Only
- HCP393 Bracket - Small Halyard Restrainer
- HFG467 Clevis Pin - 1/4" x 1.0625" 18-8
- HFS118 Cotter Pin - 1/16" x .500" 18-8

4

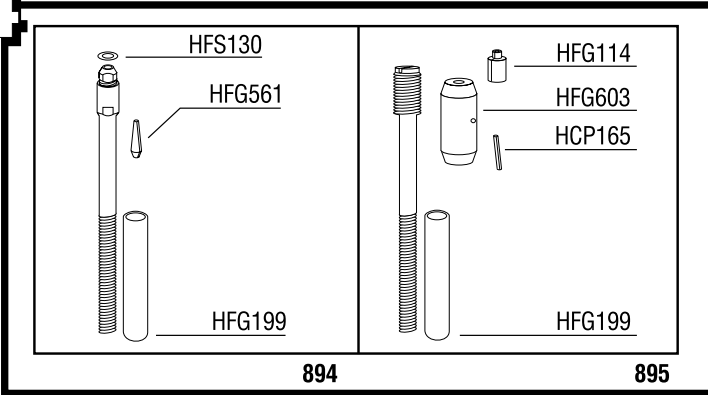

4 - Studs & Components

Sta-Lok Studs

- HFG199 Stud-Cap - 1/2" ID x 4" Red
- 894 Stud - 5/16" (8 mm) Sta-Lok
- HFG561 Wedge - 5/16" Sta-Lok
- HFG130 Washer - 3/8" .068 x .813 x .406 18-8

Rod

- HFG199 Stud-Cap - 1/2" ID x 4" Red
- 895 Stud -12 Rod Adpt w/Nosepiece
- HFG603 Stud - Main Body
- HFG114 Nosepiece -12
- HCP165 Roll Pin - 5/32" x 1.25"
- H-8396A Sleeve

5

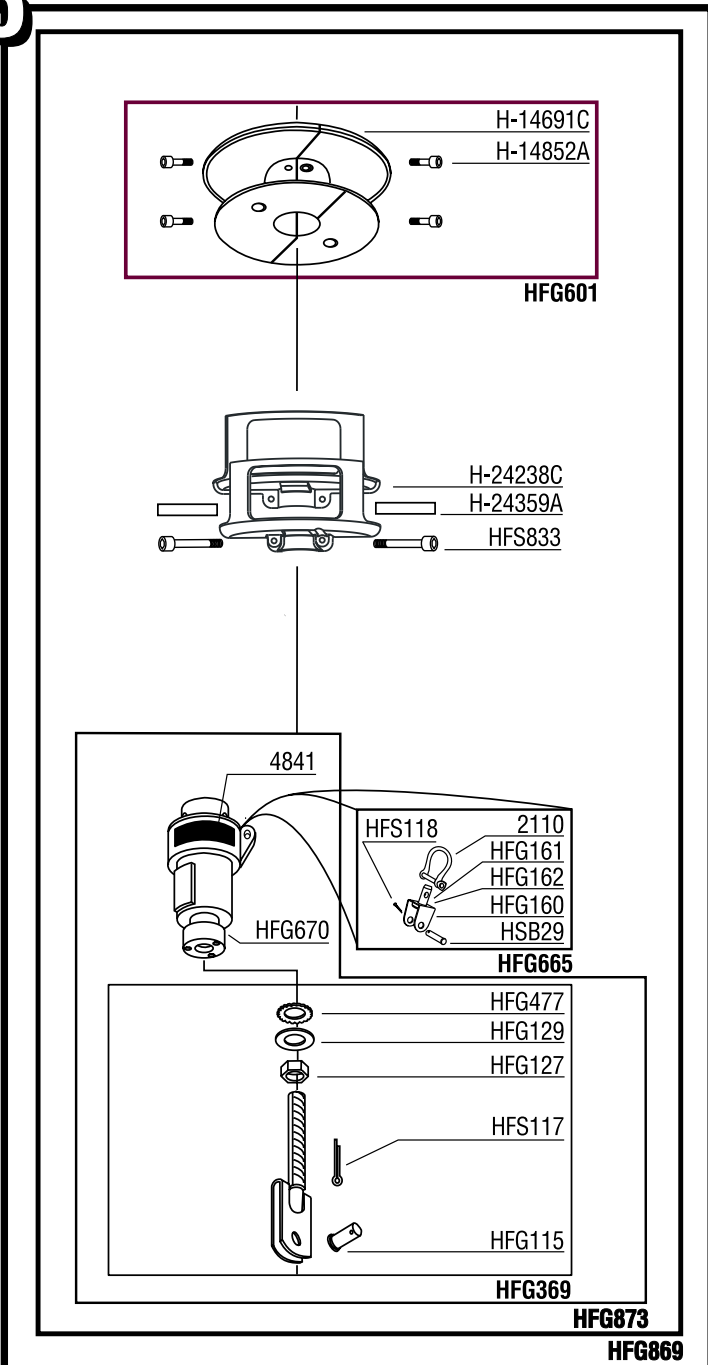

5 - Drum Assembly & Components

HFG869

- Drum Assembly - Complete
- HFG601 Spool Assembly - Complete
- H-14691C Spool Assembly Half
- H-14852A Fastener - M6 x 1.00-6G 316 (order 4)
- H-24238C Line Guard (order 2)
- HFS833 Fastener - M8 x 1.25 GC Screw (order 2)
- H-24359A Mylar Guard Clamp Shim (order 2)
- HFG873 Hub - w/Lower Toggle
- HFG369 Lower Toggle
- HFG129 Flat Washer - Lower Toggle
- HFS117 Cotter Pin
- HFG477 Lockwasher - Toggle
- HFG127 Lock Nut
- HFG115 Clevis Pin - Lower Toggle
- HFG670 Hub - w/o Lower Toggle
- 4841 Label - Tack Swivel
- HFG665 Tack Shackle Assembly
- 2110 Shackle - (6 mm) 1/4" Bow
- HFG160 Swivel Bracket
- HFG161 Swivel Pin - 1 3/32"
- HFG162 Plastic Washer
- HFS118 Pin - 1/16" x .500 18-8 Cotter
- HSB29 Clevis Pin - 1/4" x 1.000"