

1 - Upper Assembly & Components

- 854 Connector Screw Set (38)
HFG537 Fastener - 10-32 x 1/4" 18-8 Slit Ov
- 855 Wedge Set (22)
HFG216 Connector Wedge
- 865 Locking Collar - w/Insert
865Collar Collar
HFG121 Plastic Insert
- 869 Trim Cap
- 897 Extrusion - 7' Luff
- 898 Extrusion - 2' Luff
- 899 Connector - 9"
- 911 Connector - 11.355" Bottom
- 912 Halyard Swivel
4456 Label - 3/8" x 2 1/8"
868 Shackle - 5/16" Bow
878 Shackle - 1/4" Twist
HCP723 Snap Ring - Large (order 2)
HCP722 Snap Ring - Small
HBB7 Ball Bearing - 3/8" Torlon (order 92)
- 927 Torque Tube
4753 Label - Small Red Oval
HFG730 Set Torque Tube Clamp Screws (2)
HFS335 Fastener - M8x1.25x35 316 Sk Cap
- 939 Feeder
HFS192 Fastener - 10-32 x 3/8" 18-8 Slit Ov (order 92)
- HFG137 Extrusion Set (8 Long, 1 Short)
897 Extrusion - 7' Luff
898 Extrusion - 2' Luff
- HFG635 Fastener Set - Torque Tube (3)
HFS336 Fastener - M8x1.25x16 A4 Sk Cap

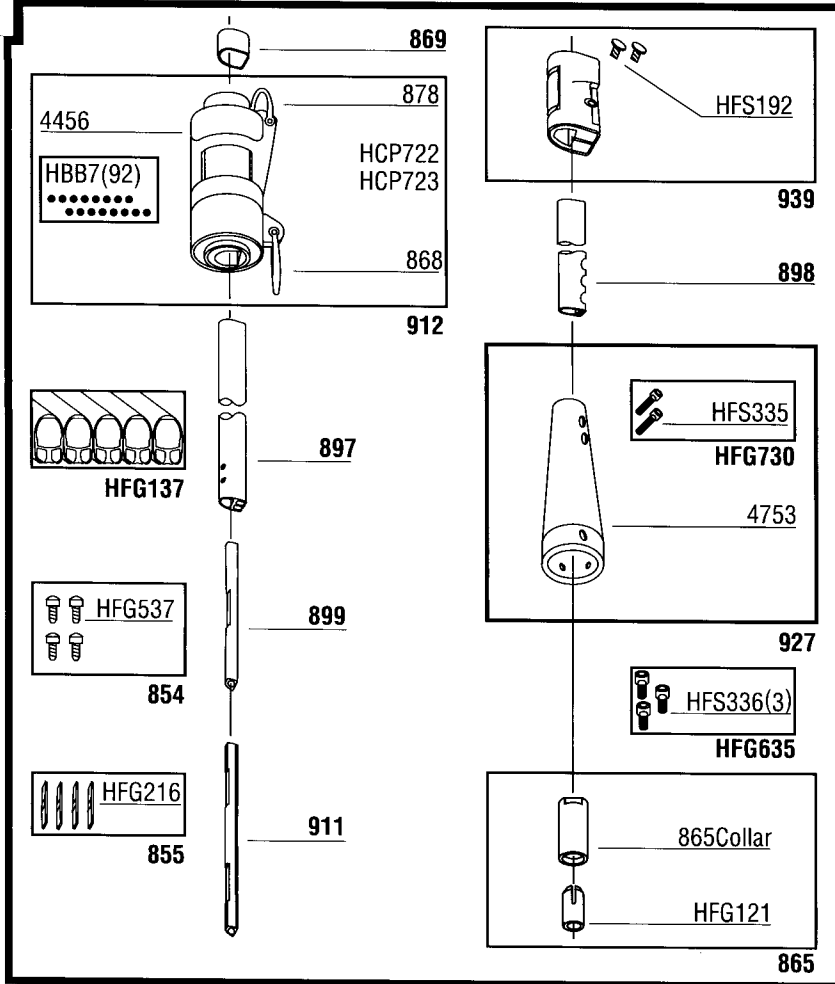

2 - Accessories

- 4115 Manual - Furling
- 833 Loctite - Blue
- 848 Line - 2 3/8" x 100'
- 867 Loctite - 2 Red
- 872 Super Glue
- 947 Prefeeder - Phenolic w/Line
- HFG636 Fastener Set - Spare
- HFG643 Wrench - M5 Allen Short
- HFG644 Wrench - M6 Allen Short
- HFG646 Wrench - M8 Allen Long

3 - Optional Parts

- 267 Kit - Small Lead Block
019A Block - 2.25" Hex Stbd
061 Stanchion Mount Base
168A Block - Bullet Swivel
HCP168 Cleat - 4" Black
- 942 Isomat Adapter
- 945 Halyard Restrainer - Small
945A Sheave & SS Inner Race Only
HCP208 Clevis Pin - 5/16" x 1.250" 18-8
HCP394 Bracket - Small Halyard Restrainer
HFS181 Cotter Pin - 3/32" x .750" 18-8

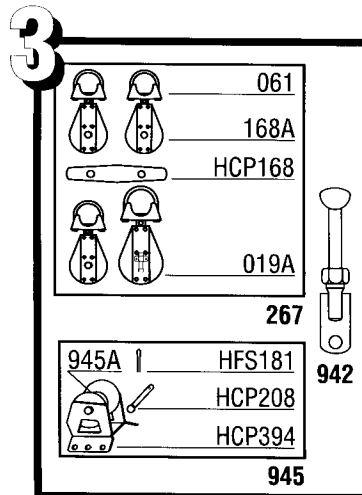
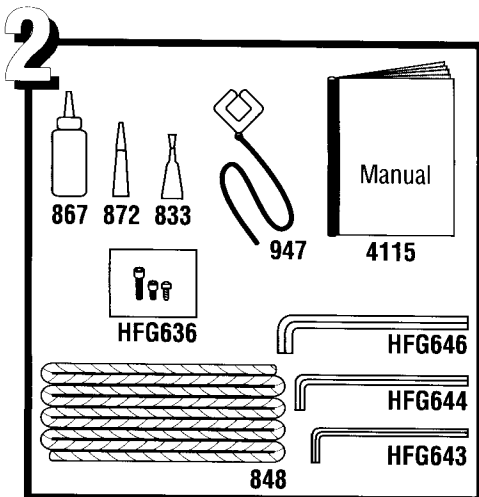

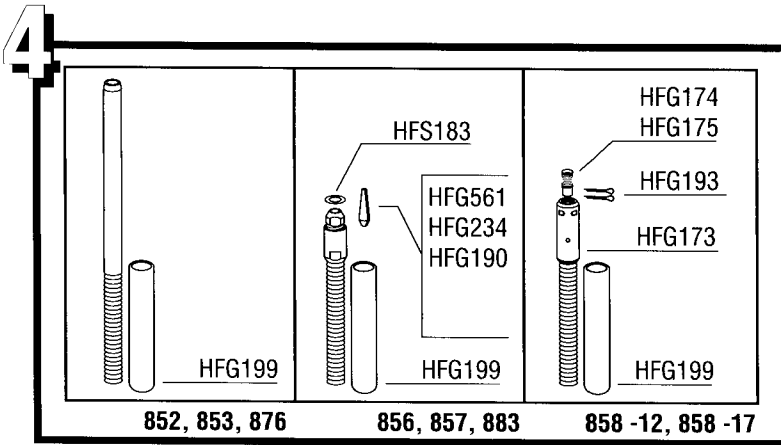

4 - Studs & Components

Swage Studs

- HFG199 Stud-Cap - 5/8" ID x 4" Red
- 852 Stud - 5/16" (8 mm) Swage
- 853 Stud - 3/8" (5 mm) Swage
- 876 Stud - 10 mm Swage

Sta-Lok Studs

- HFG199 Stud-Cap - 5/8" ID x 4" Red
- 856 Stud - 5/16" (8 mm) Sta-Lok
- HFG561 Wedge - 5/16" (8 mm) Sta-Lok
- HFS183 Washer - 3/8" .068 x .813 x .406 18-8
- 857 Stud - 3/8" Sta-Lok
- HFG234 Wedge - 3/8" Sta-Lok
- HFS183 Washer - 3/8" .068 x .813 x .406 18-8
- 883 Stud 10 mm Sta-Lok
- HFG190 Wedge - 10 mm Sta-Lok
- HFS183 Washer - 3/8" .068 x .813 x .406 18-8

Rod

- HFG199 Stud-Cap - 5/8" ID x 4" Red
- 858 -12 Stud -12 Rod Adpt w/Nosepiece
- HFG173 Stud - Main Body
- HFG174 Nosepiece -12
- HFG193 Cotter Pin - 3/32" x 1" 18-8
- 858 -17 Stud -17 Rod Adpt w/Nosepiece
- HFG173 Stud - Main Body
- HFG175 Nosepiece -17
- HFG193 Cotter Pin - 3/32" x 1" 18-8

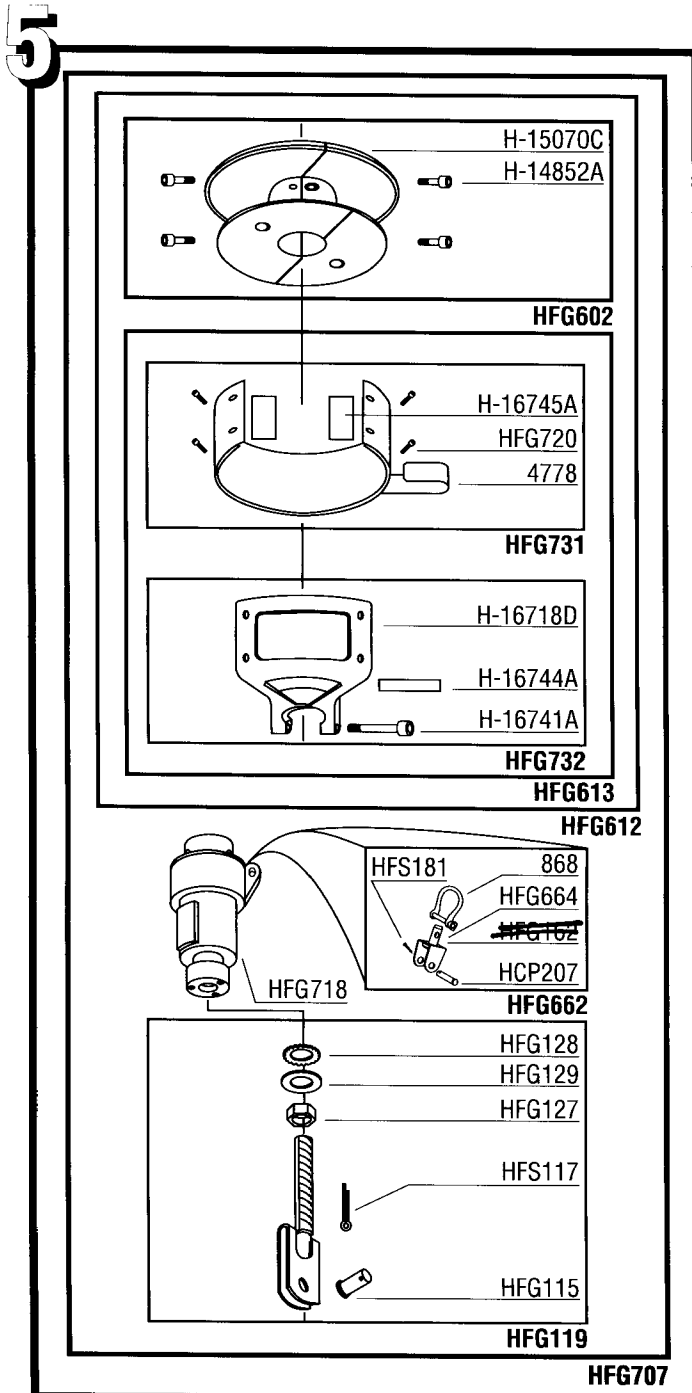

5 - Drum Assembly & Components

HFG707

- HFG707 Hub Complete
- HFG612 Cowling - w/Guard & Spool
- HFG602 Spool Assembly - Complete
- H-14852A Fastener - M6 x 1.00-6G 316 (order 4)
- H-15070C Spool Assembly Half
- HFG613 Cowling - w/Guard
- HFG731 Cowling - w/Shims & Fst
- 4778 Label - Cowling
- HFG720 Fastener Set - Guard
- H-16745A Mylar Cowling Shim (order 2)
- HFG732 Guard - w/Shims & Fastener
- H-16718D Line Guard
- H-16741A Fastener - M10 x 1.50 GC Screw
- H-16744A Mylar Guard Clamp Shim
- HFG119 Lower Toggle
- HFG115 Clevis Pin - Lower Toggle
- HFS117 Cotter Pin
- HFG127 Lock Nut
- HFG128 Lockwasher - Toggle
- HFG129 Flat Washer - Lower Toggle
- HFG718 Hub - w/o Lower Toggle
- HFG662 Swivel Bracket Assembly
- 868 Shackle - 3/16" Bow
- HFG664 Swivel Bracket w/swivel pin
- HCP207 Clevis Pin - 5/16"
- ~~HFG102~~ Plastic Washer
- HFS181 Cotter Pin - 3/32" x .750 18-8