



8000 Gypsy/Drum Windlass Installation Manual

Issue B

LEWMAR®

PART 1 - HYDRAULIC ANCHOR WINDLASS INSTALLATION

VERTICAL HYDRAULIC MODELS

- Windlass Installation**
- 1 Remove the anchor windlass from the packing case. Ensure that you have the necessary parts required to complete your system.

There are three items to position, the windlass, chain pipe (optional) and controls. Remember to allow space below deck for the motor - gearbox and for the connection of the hydraulic lines from the windlass to the power unit.
 - 2 Position the windlass deck unit on the deck or in the anchor well (see drawings for cut out dimensions) such that the centre - line of the chain on the gypsy aligns with the bow roller in a horizontal plane, and that the vertical line is within 10 degrees of the chain gypsy. Ensure that the chain achieves maximum contact around the chain gypsy (i.e. at least 120 and preferably 180 degrees contact).
 - 3 Cut and drill clearance holes in the deck for the windlass and chain pipe, to the size detailed on the installation template.
 - 4 Apply bedding compound onto the joint faces and mount the windlass and chain pipe with the gypsy facing pawl facing aft and the chain stripper facing forward.

Hydraulic Installation

- 5 The Lewmar 8000 hydraulic windlass is designed to be used with Lewmar Commander power packs or similar power packs that give the required flow and pressure. Plan the routing of the hydraulic lines **(including case drain lines)** and run them from the hydraulic supply to the windlass motor (see hose type recommendations).
- 6 Connect the hydraulic feed and return lines to the hydraulic windlass motor, ensuring that the connections are secure (see motor specifications).
- 7 Connect the case drain line (see case drain line specifications).
- 8 Find a suitable position for electric safety deck switch(es), remote control and / or toggle switch in view of the windlass, anchor line and bow roller. Connect up the switch wiring to the Commander system (see Commander manual) or a suitable proprietary system ensuring that the minimum supply is 3 amps. The switches require a 12V or 24V DC system depending on available supply.
- 9 Check correct operation of the windlass (eg up / down).

If the rotation is incorrect swap the A + B hoses at the motor, or swap the switch wiring, or swap the Directional Control Valve (DCV) caps.

LEWMAR®

ANCHOR WINDLASS HYDRAULIC SPECIFICATIONS

CUSTOM 8000 VERTICAL HYDRAULIC MODELS

Hydraulic Motors

The hydraulic motor is a fully reversible, high efficiency motor gearbox.

Model	Motor	Flow Min / Max (Ltr / min)	Pressure Max (Bar)
8000	500 cc/Rev	30 - 70	115 (1667 psi)

Note: (a) 3.78 litres ≈ 1 US Gallon
4.54 litres ≈ 1 Imperial Gallon
(b) 14.5 psi = 1 Bar

Anchor Windlass Specifications

Model	Max Pull	Max Line Speed	Working Load
8000	3750 kg 8267 lb	6-15 m (20-49 ft) / min	726 kg 1600 lb

Model	Line Speed @ Working load	Weight
8000	Dependant on Power Pack	260 kg / 572 lb

LEWMAR®

Hose Types

For reliable operation and safety reasons, it is essential to use the correct bore size of hose. To reduce pressure drops in hose runs greater than 5 - 7 m it is recommended a larger hose size is used.

The recommended hose bore sizes with their flow requirements are given below.

Model	Motor	Flow (Ltr / min)	Min Bore Size
8000	500 cc/Rev	Up to 40 Up to 70	3/4" 1"

- Note:** (a) 3.78 litres \approx 1 US Gallon
4.54 litres \approx 1 Imperial Gallon
(b) It is important that the correct hose specification is used as this affects the efficiency of the hydraulic motor and the performance of the windlass.

LEWMAR®

IMPORTANT

Drain Line

To obtain optimum shaft life a case drain line **must** be fitted.

Min drain line bore diameter: 6mm (1/4")

Safe working pressure: 18 Bar (250 psi)

All drain lines should if possible be connected to the reservoir separately.

Hydraulic Fittings

The Lewmar Anchor Windlass hydraulic motors accept the following fittings:

Motor ports - 3/4" BSP Female

Case Drain - 1/4" BSP Female

Hydraulic Connections

The connection of the service lines should be plumbed in as follows: -

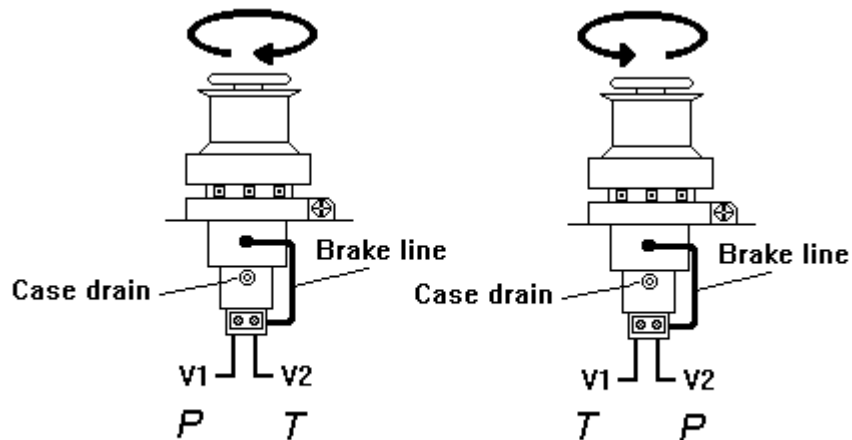

A Case Drain Line Must Be Fitted.

PART 2 - OPERATION, MAINTENANCE.

CUSTOM 8000

OPERATION OF VERTICAL HYDRAULIC MODELS

Operation Explained

The main shaft, driven by the motor / gearbox, is splined directly to the capstan. There is a fail-safe integral brake fitted to the capstan. The brake is released when hydraulic power is applied to the capstan. The gypsy can either be powered by the capstan or free running. The gypsy is powered by engaging the dog drive teeth of the capstan to those of the gypsy. Engagement and disengagement of the dog drive is controlled by turning the top nut, which lifts and lowers the capstan. Spring loading between the capstan and gypsy facilitates engagement / disengagement.

The free running gypsy is controlled by tightening or loosening the full wrap brake band.

Power Up

Press the deck switch, remote control or toggle switch (Anchor Up).

NOTE: Ensure that the brake band is released and that the dog drive is fully engaged.

Power Down

Press the deck switch, remote control or toggle switch (Anchor Down).

NOTE: Ensure that the brake band is released and that the dog drive is fully engaged.

Manual Chain Release

Place a Lewmar winch handle in the brake band bi – square and secure the chain gypsy. Place the Lewmar winch handle into the top nut and raise the capstan until the dog drive is fully disengaged.

Replace the handle in the brake band bi - square and carefully release the brake to allow the gypsy to run free. The descent of the chain can be controlled and stopped by tightening the band.

LEWMAR®

Capstan Operation

Gypsy / Capstan model - To use the capstan (with rope only) lock the gypsy off with the brake band to stop the chain from free running. Place a Lewmar winch handle into the top nut and raise the capstan until the dog drive is fully disengaged.

Press the Up button to power the Capstan.

Dog Drive Engagement

Place a Lewmar winch handle into the top nut and lower the capstan down onto the gypsy until resistance is felt, then backwind one quarter of a turn.

Press the Up / Down switch and the dog drive will spring down into positive engagement. Tighten down the top nut securely if required.

Once the dog drive has been fully engaged, stop power operation and release the brake band before powered operation is continued.

Warning !

Ensure that the dog drive is fully engaged when powering in or out.

Keep hands and feet clear of free running chain.

Do not leave a winch handle in the windlass while operating.

Classification society rules require that a vessel lying at anchor should have its chain held by a cable / chain stopper or equivalent strong point as a windlass should not be subjected to the loads generated under storm conditions.

We recommend that the vessels engine should always be used to aid anchor recovery.

Do not attempt to pull a load greater then the rated load of the windlass.

When the windlass is not in use the anchor must be tied off onto a cleat or equivalent strong point to prevent damage to the vessel.

Maintenance

The windlass is housed in the harshest environment on the vessel. The windlass should be checked and cleaned every six months. Wash away salt deposits using fresh water, clean and grease the main shaft, spline and bearings (using marine grade grease).

Remove the brake band assembly, clean brake band and gypsy (**Do not allow grease onto the brake band surface**). Check for wear and replace if necessary.

Check the motor / gearbox for signs of corrosion. If corrosion is evident, clean and repaint with a marine grade oil based enamel paint.

LEWMAR®

PART 3 - PARTS LIST, TECHNICAL DRAWINGS

SPARE PARTS LIST

8000	Part No	Description	Qty
Windlass	15001459	Support Pin	3
	15001461	Friction Plate	1
	15044121	Roller Bearing	6
	65000405	Brake Band Cover Mk II	1
	65000406	Centre Stem Mk II	1
	65000407	Drive Shaft Mk II	1
	65000411	Support Plate Mk II	1
	65000412	Adjusting screw Mk II	1
	65000413	Chain Stripper Mk II	1
	65000423	Cleat Nut 8000	1
	65000444	Top Bolt Mk II	1
	65000449	Spacer Mk II	2
	65000466	Pivot C / Bored Mk II	1
	65000467	Pivot Threaded Mk II	1
	65000480	Collet Ring Mk II	2
	65000483	Bearing Retainer Mk II	1
	65000545	Pillar Mk II	2
	65000594	Washer	2
	65000597	Sleeve	4
	65000793	Hollow Dowel	4
	65000798	Drum AW	1
	65000858	Base	1
	65000883	Spacer	1
	68000243	Brake Band Assembly	1
	B1798	Spring	4
	B7789	Spiral Ext Clip	1
	B8315	O ring 139.5 x 3.0	1
	B8983	Rotary Seal	1
	B9294	Brake Hose Assembly	1
	B9397	Motor GearBox/Brake	1
	B9467	Motor Valve Assembly	1
	Gypsy Kits	60000004	16mm Shortlink
60000143		19mm Shortlink	

6000 / 8000 / 10000 HYDRAULIC AW

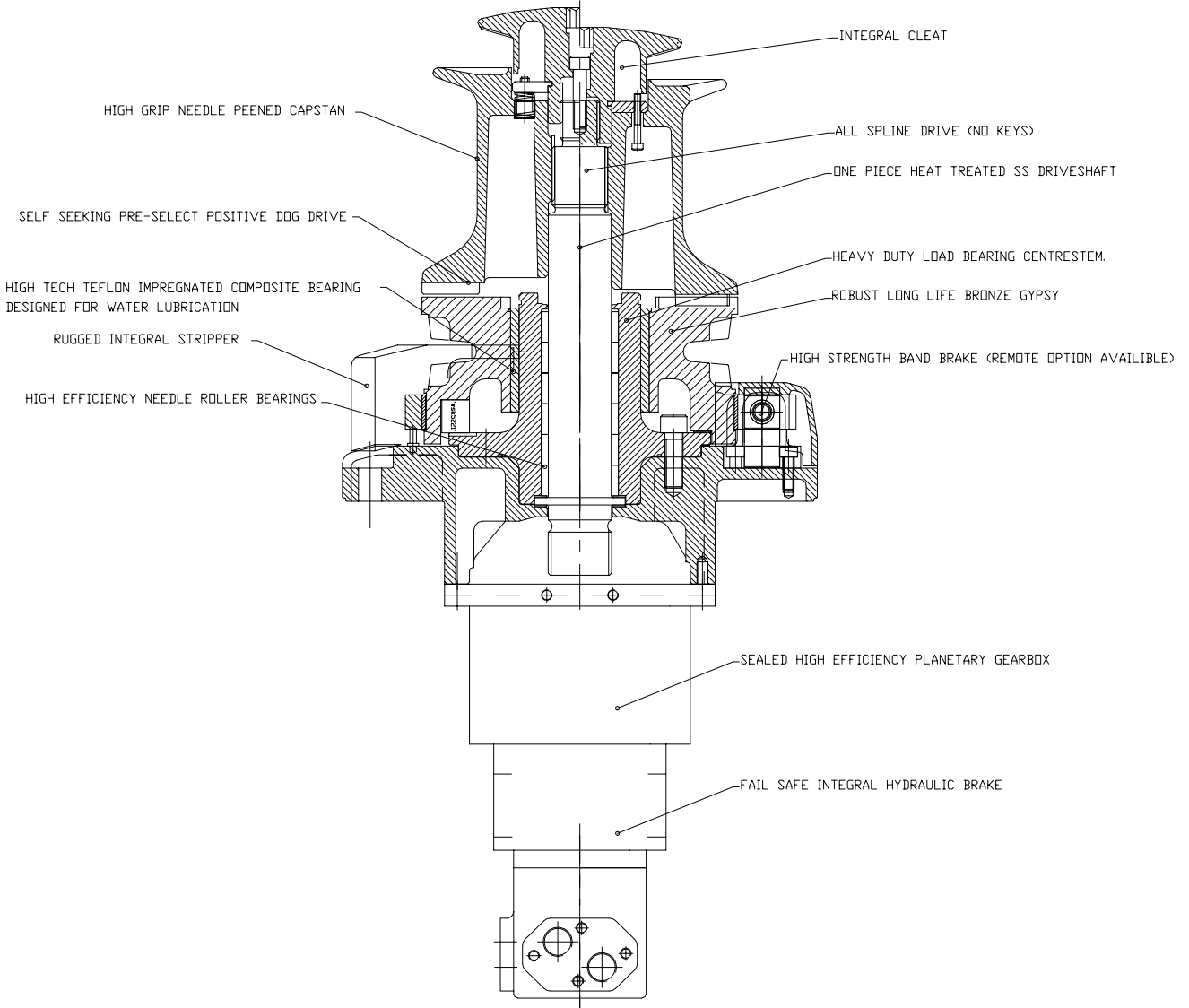

HIGH GRIP NEEDLE PEENED CAPSTAN
 SELF SEEKING PRE-SELECT POSITIVE DOG DRIVE
 HIGH TECH TEFLON IMPREGNATED COMPOSITE BEARING
 DESIGNED FOR WATER LUBRICATION
 RUGGED INTEGRAL STRIPPER
 HIGH EFFICIENCY NEEDLE ROLLER BEARINGS

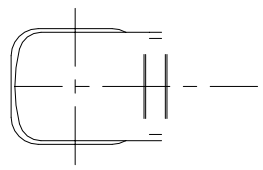
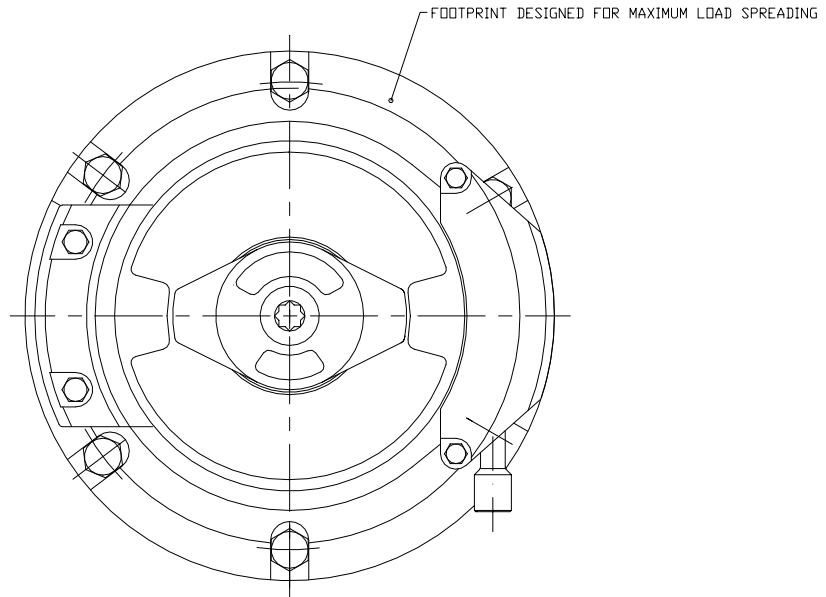

8000 AW MK2

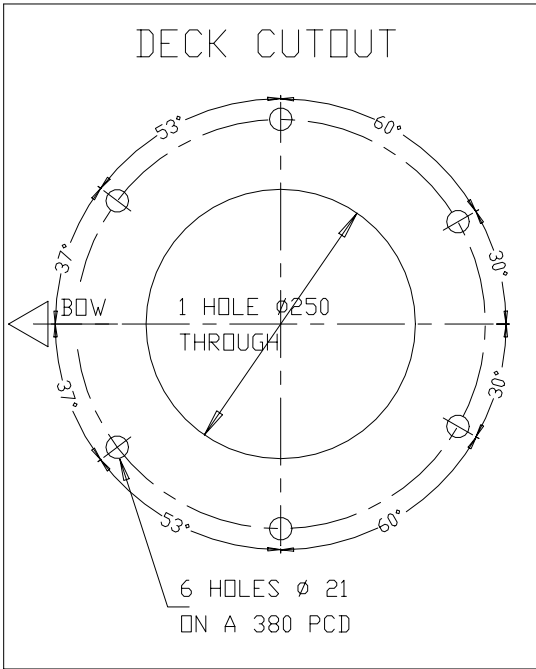

8000 ANCHOR WINDLASS SPECIFICATION

MOTOR : ADAN MGF 5B 500T

MAX FLOW : 75 L/MIN = 21 M/MIN GYPSY CHAIN SPEED
 17 M/MIN CAPSTAN ROPE SPEED

PRESSURE : 125 BAR (MAX CONT PULL)
 3100 KG (6820 LB) GYPSY
 3900 KG (8580 LB) CAPSTAN

WEIGHT : 190 KG (420 LB)

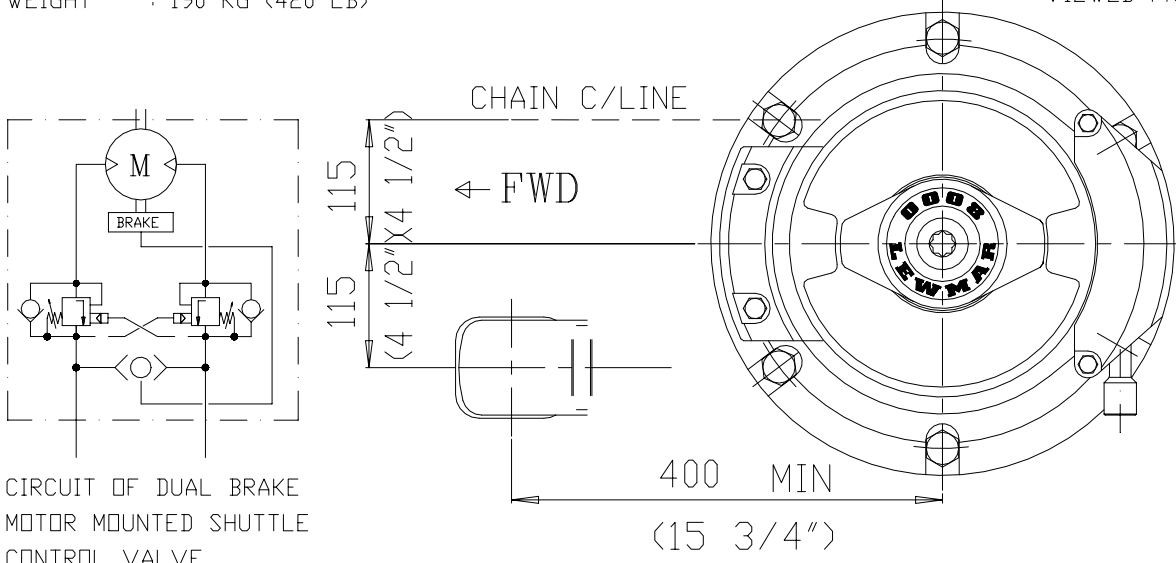
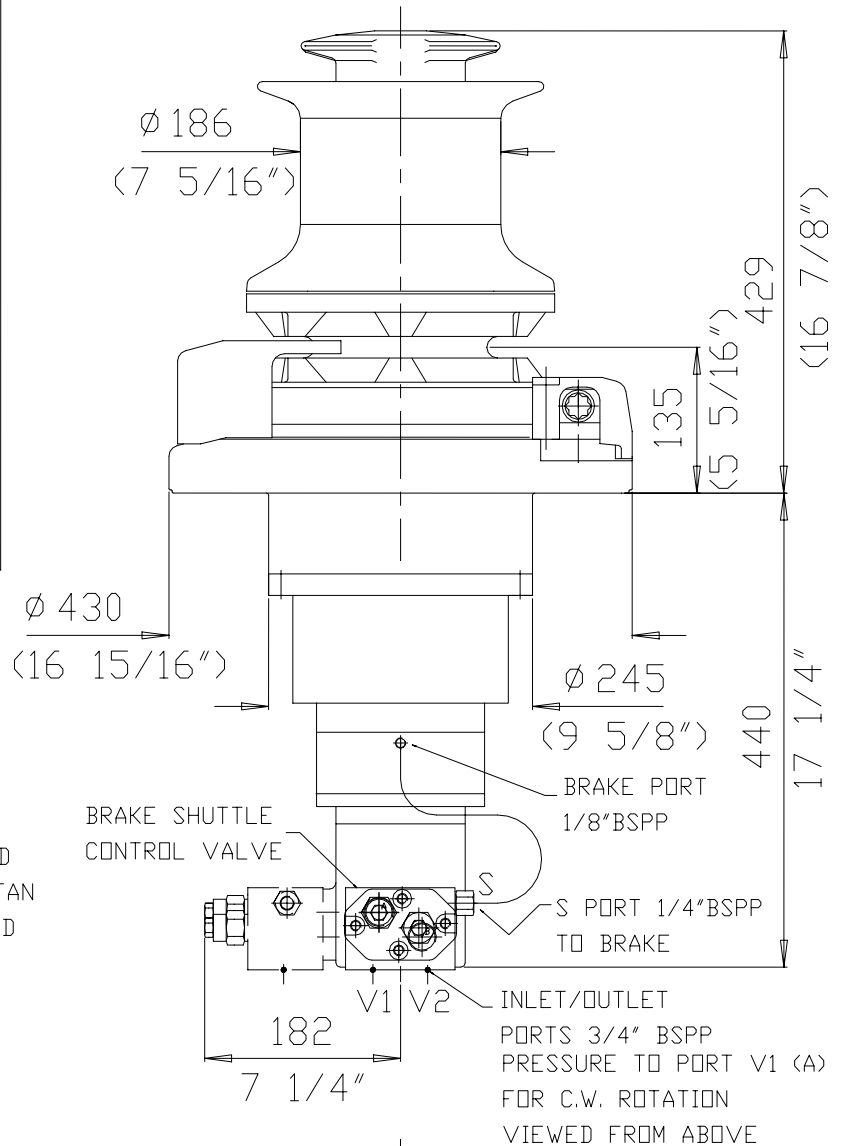

L.H. VERSION SHOWN

4 HOLES: M6 X 1.0-6H
X 12 DEEP FULL THREAD

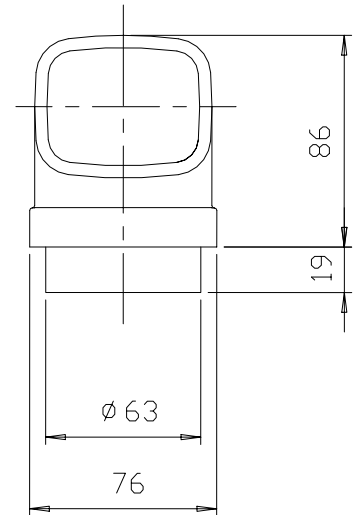
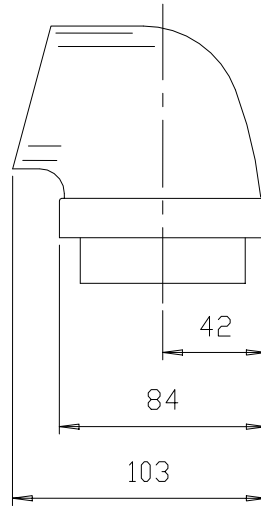
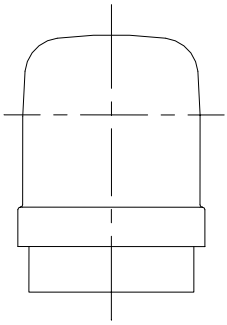
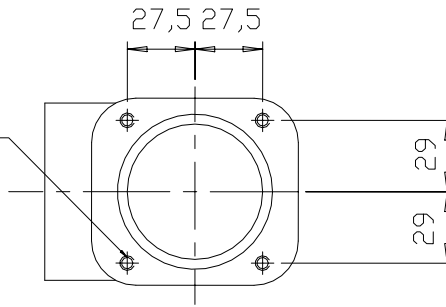

8-13mm REMOTE CHAINPIPE
68000024

4 HOLES: M8 X 1.25-6H
X 14 DEEP FULL THREAD

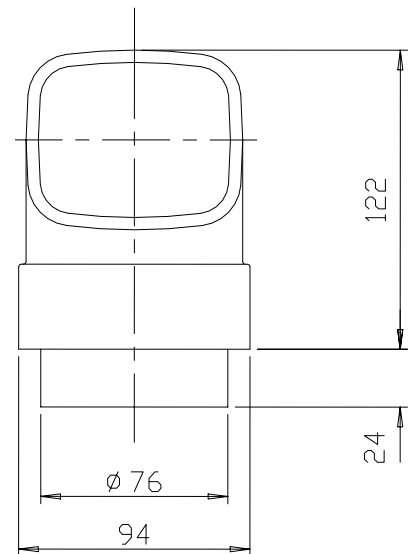
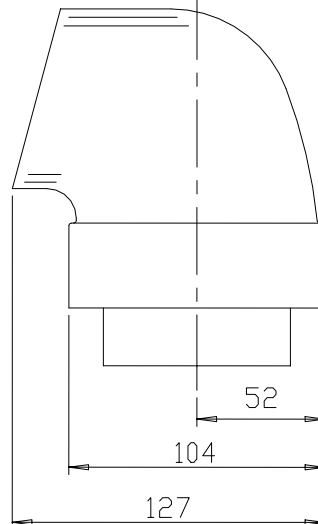
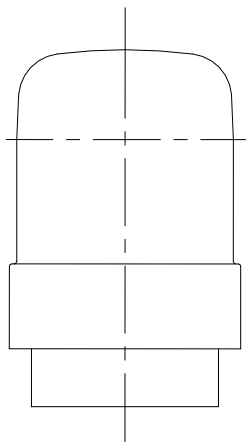
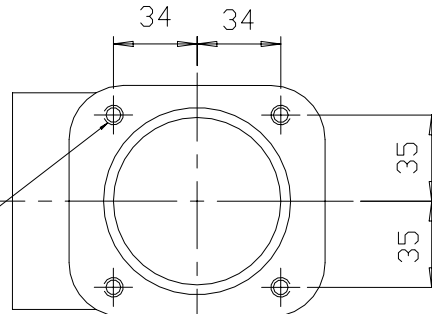

14-16mm REMOTE CHAINPIPE
68000037 - CH

68000314 - BR

DRN	AMCC.
DATE	21.02.94

DRG. No	WSD0237
---------	---------

LEWMAR

LEWMAR LIMITED WARRANTY

Lewmar warrants its products in normal usage to be free of defects in materials and workmanship for a period of three years from date of purchase by the original purchaser, subject to the conditions, limitations and exceptions listed below. Any part, which proves to be defective in normal usage during that three-year period, will be repaired or at Lewmar's option, replaced by Lewmar.

A CONDITIONS AND LIMITATIONS

- i Lewmar's liability shall be limited to repair or replacement of the goods or parts defective in materials or workmanship.
- ii Determination of the suitability of the material for the use contemplated by the buyer is the sole responsibility of the buyer and Lewmar shall have no responsibility in connection with such suitability.
- iii Lewmar shall not be liable in any way for:
 - a Failures, loss or damage due to use of products in applications for which they are not intended.
 - b Failures, loss or damage due to corrosion, ultra violet degradation, wear and tear or improper installation.
 - c Failures, loss or damage due to incorrect maintenance.
 - d Failures, loss or damage due to conditions that exceed the product's performance specifications.
- iv Product subject to warranty claim must be returned to Lewmar for examination unless otherwise agreed by Lewmar in writing.
- v Lewmar shall not be responsible for shipping charges nor installation labour associated with any warranty claim.
- vi Service by anyone other than authorised Lewmar representatives shall void this warranty unless it accords with Lewmar guidelines and standards of workmanship.
- vii Lewmar's products are intended for use only for marine purposes. Buyers intending to use them for any other purpose should seek advice from Lewmar, and Lewmar shall be under no liability arising from use, which Lewmar has not approved.

B EXCEPTIONS

Warranty is limited to a period of one year from the date of purchase in the case of the following:

- Bow thrusters
- Electric motors and electrical equipment
- Electronic controls
- Hydraulic pumps, valves and actuators
- Weather seals
- Products used in "Grand Prix" racing applications

C LIABILITY

- i Lewmar's liability under this warranty shall be to the exclusion of all other warranties or liabilities (to the extent permitted by law). In particular (but without limitation):
 - a Lewmar shall not be liable for:
 - Any indirect or consequential loss including (without limitation) any loss of anticipated profits, damage to reputation or goodwill, loss of expected future business, damages, costs or expenses payable to any third party or any other indirect losses.
 - Any damage to yachts or equipment.
 - Death or personal Injury (unless caused by Lewmar's negligence).
 - b Lewmar grants no warranties regarding the fitness for purpose, use, nature or satisfactory quality of the goods.
- ii Where the laws of the country do not permit a warranty to be excluded, then such warranty, if permitted by that country's law, shall be limited to a period of one year.

LEWMAR CONTACT DETAILS

LEWMAR SALES OFFICES

Lewmar UK/Rest of World

Lewmar Ltd, Southmoor Lane, Havant, Hampshire PO9 1JJ. UK

Tel (+44) 23 92 485700 Fax (+44) 23 92 485710

e-mail info@uk.lewmar.com

Lewmar USA

Lewmar Inc, New Whitfield Street, Guilford, CT 06437, USA

Tel (+1) 203 458 6200 Fax (+1) 203 453 5669

e-mail info@usa.lewmar.com

Lewmar Mid Europe

Lewmar Ltd, Branderweg 19, 8042 PD Zwolle, The Netherlands

Tel (+31) 38 427 34 90 Fax (+31) 38 421 56 42

e-mail info@holland.lewmar.com

Lewmar Southern Europe

Lewmar Ltd, Place Bernard Moitessier, 17000 La Rochelle, France

Tel (+33) 5 46 50 50 46 Fax (+33) 5 46 50 59 04

e-mail info@france.lewmar.com

Lewmar Southern Europe (Cannes)

Lewmar Ltd, Allée Charles Nungesser, Parc D'Activités de la Siagne 06210 Mandelieu, France

Tel (+33) 4 93 48 80 48 Fax (+33) 4 93 48 37 50

e-mail info@france.lewmar.com

Lewmar Southern Europe (Spain)

Lewmar Ltd, Sucursal en Espana, Joan de Borbó 92,

08039 Barcelona, Spain

Tel (+34) 93 221 94 37 Fax (+34) 93 225 19 49

e-mail info@spain.lewmar.com

Lewmar Northern Europe

Lewmar Marin AB, Argongatan 8, S-431 53, Mölndal, Sweden

Tel (+46) 31 277130 Fax (+46) 31 273116

e-mail info@sweden.lewmar.com

Lewmar Northern Europe (Finland)

Lewmar Marin AB (Finland), Laaksoitie 10 A-B, 02700 Kauniainen, Finland

Tel (+358) 9 5489 5110 Fax (+358) 9 5489 5111

e-mail info@finland.lewmar.com