

Two Speed Self-Tailing Winch 40.2st

HARKEN®

Winch Parts and Service Instructions

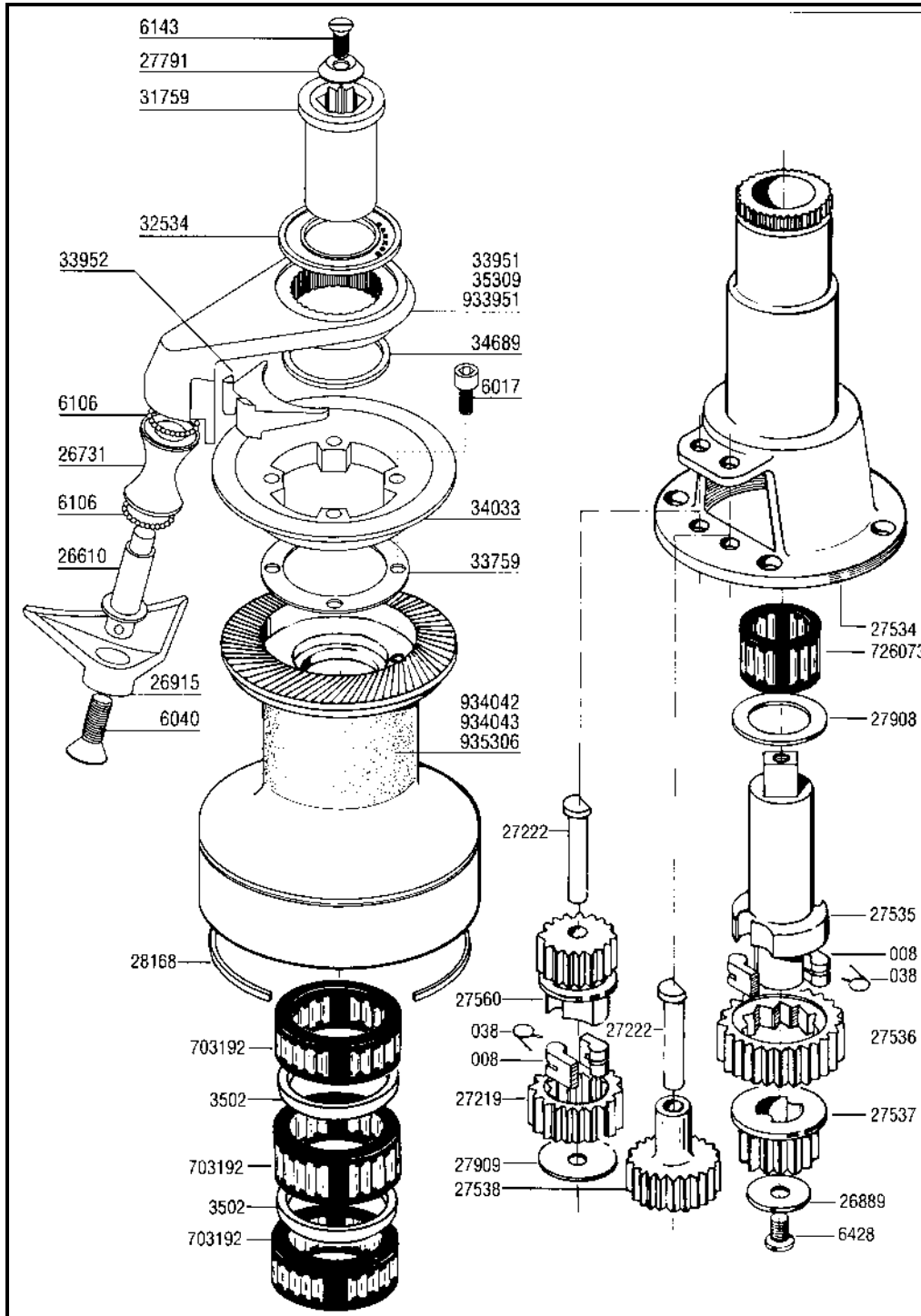

When ordering parts for service, please include a "B" before each number (i.e. B008).

Tools Required

Screwdriver
Allen Wrench (5mm)
Plastic Head Hammer or Mallet
Small Knife
Brush
Rags
Solvent
Oil
Grease

Parts List

008	Pawl
038	Pawl Spring
3502	Bearing Spacer
6017	Screw
6040	Screw
6106	Ball (32 required)
6143	Top Screw
6428	Screw
26610	Roller Shaft
26731	Roller
26889	Cover Plate
26915	Guide Arm
27219	Ratchet Gear
27222	Gear Shaft
27534	Center Stem
27535	Spindle
27536	Ratchet Gear
27537	Gear
27538	Gear
27560	Pawl Gear
27791	Plastic Washer
27908	Washer
27909	Cover Plate
28168	Red Line Ring
31759	Handle Socket
32534	Top Cap
33759	Adjustment Spacer
33951	Chrome Stripper Arm
33952	Line Peeler
34033	Upper Jaw
34689	Plastic Washer
35309	Bronze Stripper Arm
703192	Bearing
726073	Bearing
933951	Chrome Stripper Arm Assembly
934042	Aluminum Drum
934043	Chrome Drum
935306	Bronze Drum

Suggested Service Kits

BK4512	10 Pawls 008
	10 Springs 038
BK4513	100ml Grease

Recommended Service Cycle – Service winch before the sailing season and once during.

Adjusting Self-Tailer

Self-tailing winches must be adjusted for line size to insure proper operation. If the line slips in the jaws, remove the adjustment spacer 33759 from under the upper jaw 34033. If the winch self-tails properly with the washer in place, do not remove it. The efficiency of the winch will be compromised when using larger lines.

Positioning Stripper Arm

Loosen top screw
 Remove handle socket
 Lift stripper arm and drum; position as desired

Opening Winch

Remove top screw
 Lift off drum and stripper arm

Servicing Winch

Remove pawls and springs - service as below
 Remove bearing, gear shaft and gears
 To reach interior shaft bearing, winch must be removed from deck
 Clean all parts with rags and solvent
 Use a brush to lubricate all moving parts lightly with grease
 Replace pawls and springs and lubricate lightly with oil
 Reassemble and close winch

Servicing Pawls

Catch spring with knife and hold against pawl
 Lift out pawl
 Clean and check for wear
 Place spring against pawl with straight leg against pawl
 Hold spring closed and slip pawl into pawl socket
 Lubricate pawls using oil

Fitting on Boat

Make sure mounting surface is flat
 Check sheet entry angle
 Open winch
 Position winch on deck with drive gear where sheet enters winch drum and mark holes
 Remove winch and drill holes
 Mount using five 1/4" (6mm) flat head machine screws
 Apply bedding compound and bolt winch to boat
 Clean excess bedding compound from base drain holes
 Lubricate and reassemble winch

Adjusting Self-Tailer

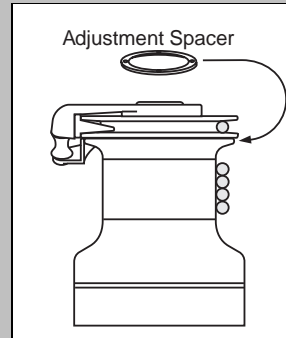

Remove or add adjustment spacer.

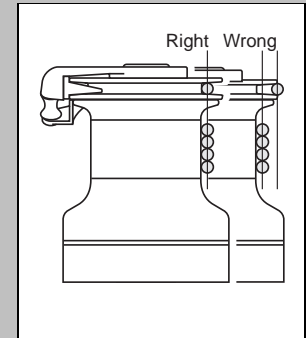

Correct opening: Sheet fits completely into jaw and rests against drum.

Servicing Winch



Clean all parts with solvent.

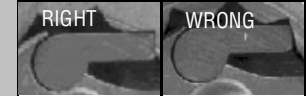
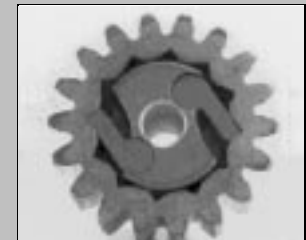

Attention: Ratchet gear mounted backwards will cause winch to slip.



Grease lightly and spread grease evenly. Use a brush.

Servicing Pawls



Use knife to free captive spring.

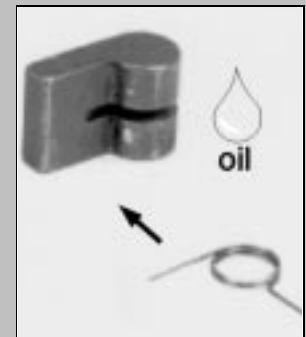

Insert spring with straight leg against pawl. Use oil for lubrication.

Fitting on Boat

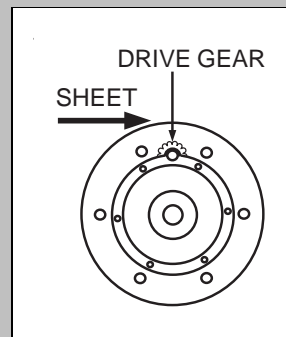

Position drive gear where sheet enters winch drum.

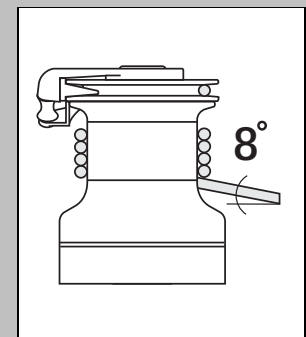

Sheet entry angle must be at least 8°.