

40.2st

Two Speed Self-Tailing Winch

Winch Parts Installation Service

HARKEN®

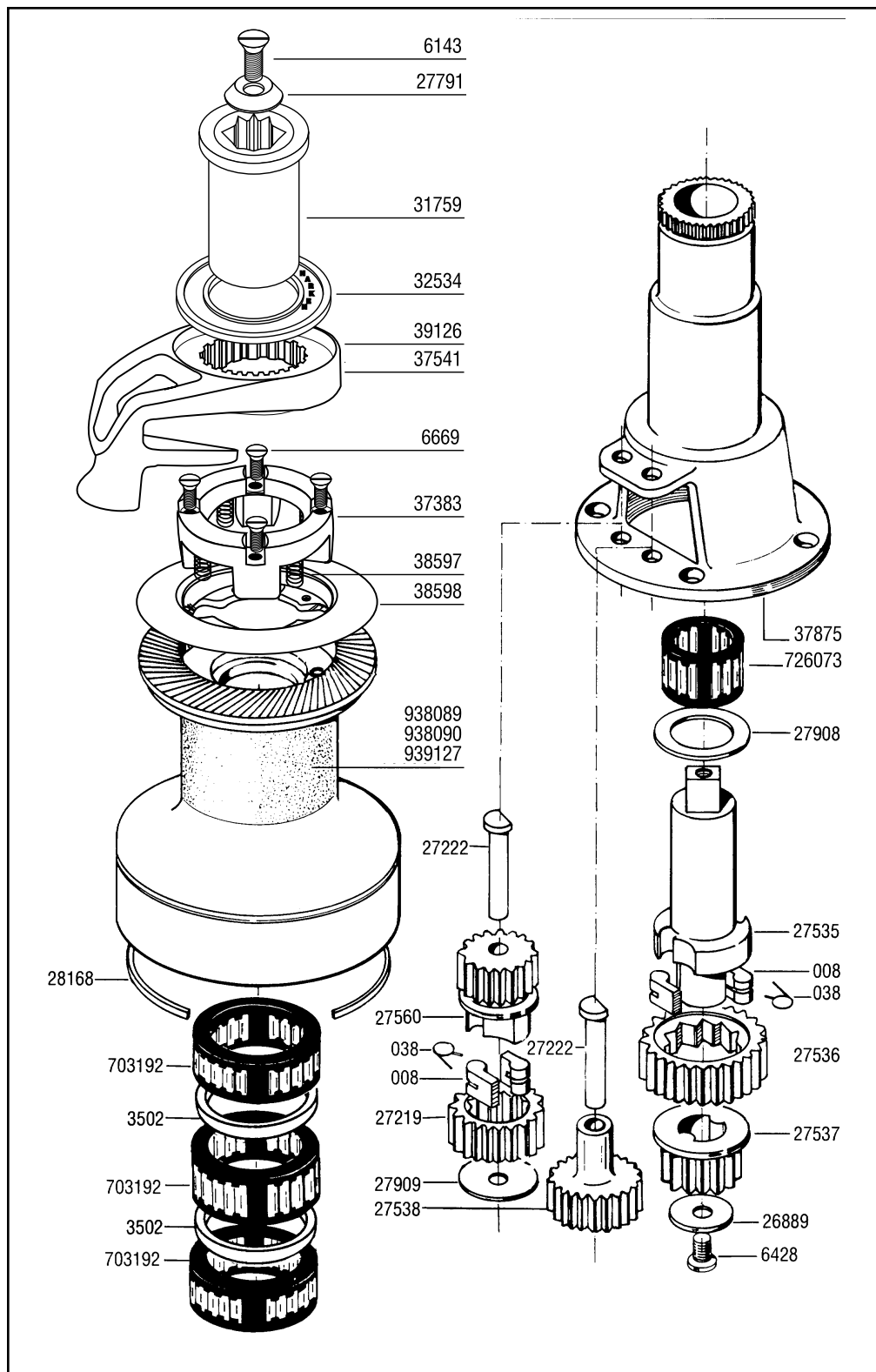

Required Tools

Screwdriver
Plastic Head Hammer or Mallet
Small Knife
Brush
Rags
Solvent
Oil
Grease

Parts List

008	Pawl
038	Pawl Spring
3502	Bearing Spacer
6143	Top Screw
6428	Screw
6669	Screw
26889	Cover Plate
27219	Ratchet Gear
27222	Gear Shaft
27535	Spindle
27536	Ratchet Gear
27537	Gear
27538	Gear
27560	Pawl Gear
27791	Plastic Washer
27908	Washer
27909	Cover Plate
28168	Red Line Ring
31759	Handle Socket
32534	Top Cap
37383	Springs Support
37541	Chrome Stripper Arm
37875	Center Stem
38597	Spring
38598	Upper Jaw
39126	Bronze Stripper Arm
703192	Bearing
726073	Bearing
938089	Aluminum Drum
938090	Chrome Drum
939127	Bronze Drum

Suggested Service Kits

BK4512	10	008 Pawls
	10	038 Springs
BK4513		100 ml Grease

When ordering parts, please include a "B" before each number (i.e. B008).

Service winch before the sailing season begins and once during.

■ Installing Winch

Make sure mounting surface is flat.
 Check sheet entry angle. Should be at least 8° (see drawing).
 Open winch.
 Position winch on deck with drive gear where sheet enters winch drum. Mark holes.
 Remove winch and drill holes.
 Mount using five (5) 1/4" (6 mm) flathead machine screws.
 Apply bedding compound. Bolt winch to boat.
 Clean excess bedding compound from base drain holes.
 Lubricate and close winch.

■ Minimum/Maximum Line Diameter

Harken winches feature spring-loaded self-tailing jaws which adjust automatically to the following line sizes:

Minimum 5/16" (8 mm)
 Maximum 1/2" (12 mm)

■ Positioning Stripper Arm

Loosen top screw.
 Remove handle socket.
 Lift stripper arm and position as desired.

■ Opening Winch

Remove top screw.
 Lift off drum and stripper arm.

■ Servicing Winch

Remove pawls and springs - service as below.
 Remove bearing, gear shaft and gears.
 To reach interior shaft bearing, winch must be removed from deck.
 Clean all parts except 37383 and 38598 with rag and solvent.
Important: Use freshwater only on parts 37383 and 38598
 Use brush to lubricate all moving parts lightly with grease.
 Replace pawls and springs and lubricate lightly with oil.
 Assemble and close winch.

■ Servicing Pawls

Catch spring with knife and hold against pawl.
 Lift out pawl.
 Clean and check for wear.
 Place spring against pawl with straight leg against pawl.
 Hold spring closed and slip pawl into pawl socket.
 Lubricate pawls using oil.

Mounting

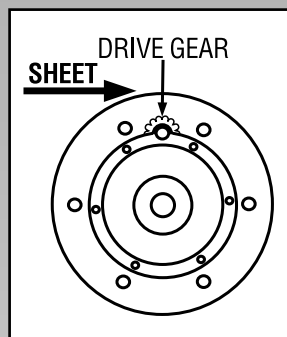

Position drive gear where sheet enters winch drum.

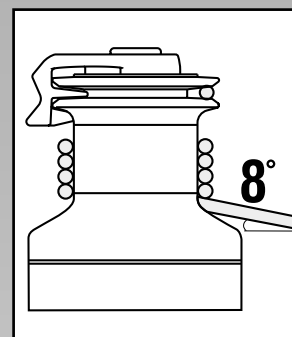

Sheet entry angle must be at least 8°.

Servicing Winch

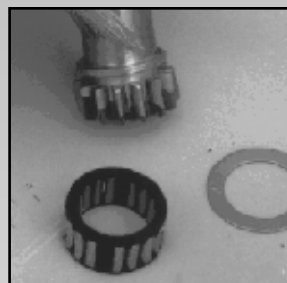

Clean all parts, except 37383 and 38598, with solvent.

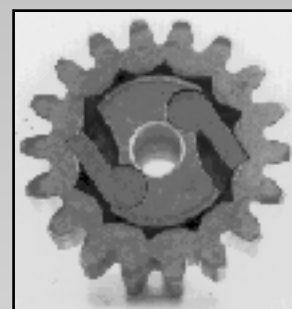

Use a brush to spread a light, even coat of grease.

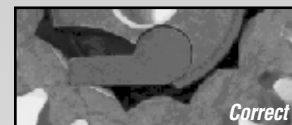

If ratchet gear is mounted backwards, winch will slip.

Servicing Pawls

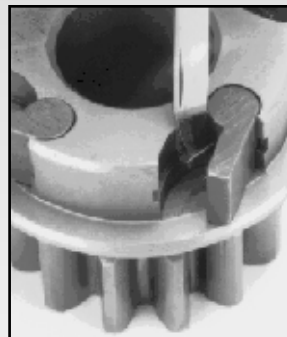

Use knife to free captive spring.

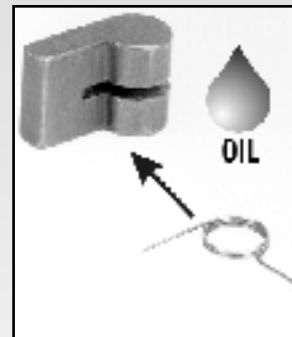

Insert spring with straight leg against pawl. Use oil for lubrication.

4562/2-99

HARKEN®

1251 E. Wisconsin Ave., Pewaukee, WI 53072 USA • Tel: (414) 691-3320 • Fax: (414) 691-3008 • Web: <http://www.harken.com> • E-main: harken@harken.com
 Via Della Cerca, 12/14, 22070 Lurago Marinone, Como, Italy • Fax: (39) 031.3520031 • Tel: (39) 031.938840 • E-mail: harken.italy@comm2000.it

